

DRAWING NOTES

- ① 2" TYPE "E" ASPHALTIC SURFACE MIX
- ② 6" STONE BASE (33-P*), 95% STANDARD PROCTOR
- ③ 1 1/2" TYPE "E" ASPHALTIC SURFACE MIX
- ④ 2 1/2" MODIFIED "B" ASPHALTIC BINDER
- ⑤ 10" STONE BASE (33-P*), 95% STANDARD PROCTOR
- ⑥ 6" CLASS "A" CONCRETE, 4,000 P.S.I. MINIMUM
- ⑦ 4" STONE BASE (33-P*), 95% STANDARD PROCTOR
- ⑧ 8" CLASS "A" CONCRETE, 4,000 P.S.I. MINIMUM
- ⑨ TACK COAT - 0.05 GAL./S.Y., AC 20

GENERAL REQUIREMENTS

- 1. SEE SD-307.01, SD-308.01, AND SD-308.02 FOR BACKFILL REQUIREMENTS FOR THE TRENCH BELOW THE SURFACE.
- 2. SURFACE REPAIR SHALL BE DONE TO A SAWCUT EDGE 6" BEYOND THE TRENCH ON ALL SIDES OF THE REPAIR.
- 3. ALL REPAIRS SHALL MEET THE MINIMUM REQUIREMENTS AS SHOWN ON THIS DRAWING OR THOSE REQUIREMENTS OF PRESENT CONDITIONS, WHICHEVER IS GREATER.

* "33-P (PUG)" - 303-01, TYPE A, GRADING D ("33-P"), TENNESSEE D.O.T. SPECIFICATIONS

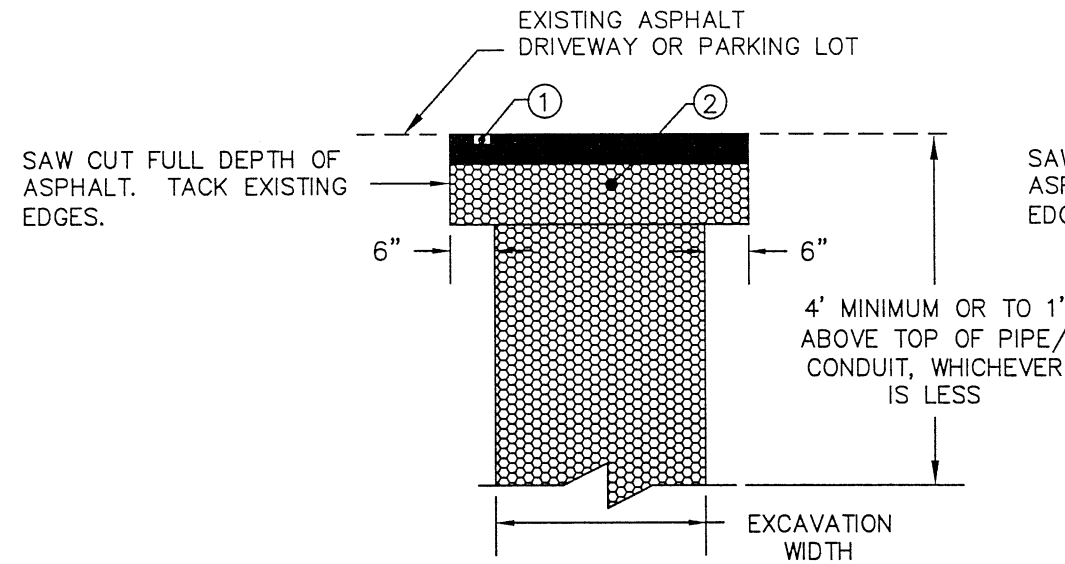

ASPHALT REPAIR

RESIDENTIAL DRIVEWAY AND LIGHT DUTY PARKING LOT

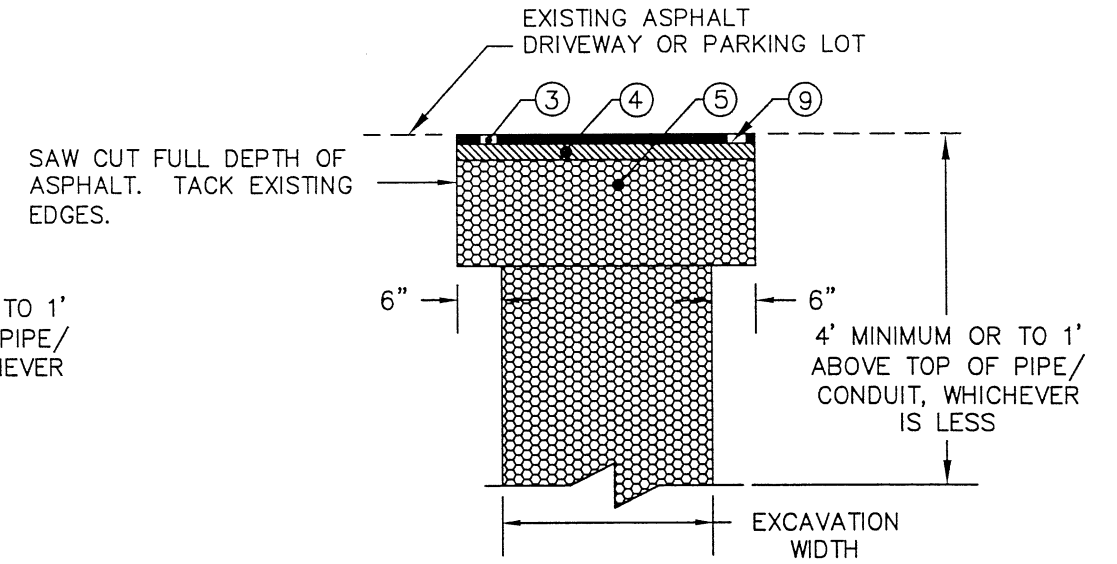

ASPHALT REPAIR

COMMERCIAL DRIVEWAY AND HEAVY DUTY PARKING LOT

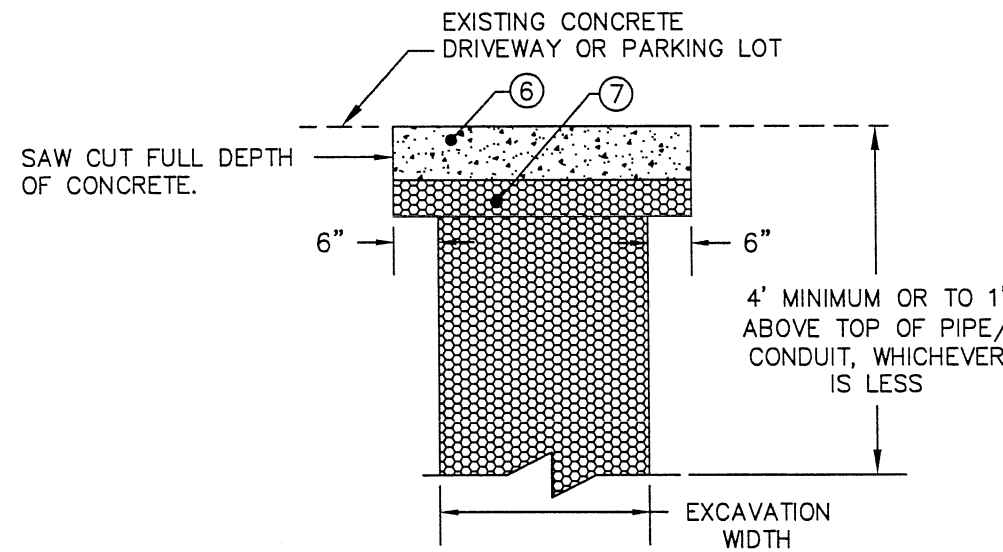

CONCRETE REPAIR

RESIDENTIAL DRIVEWAY AND LIGHT DUTY PARKING LOT

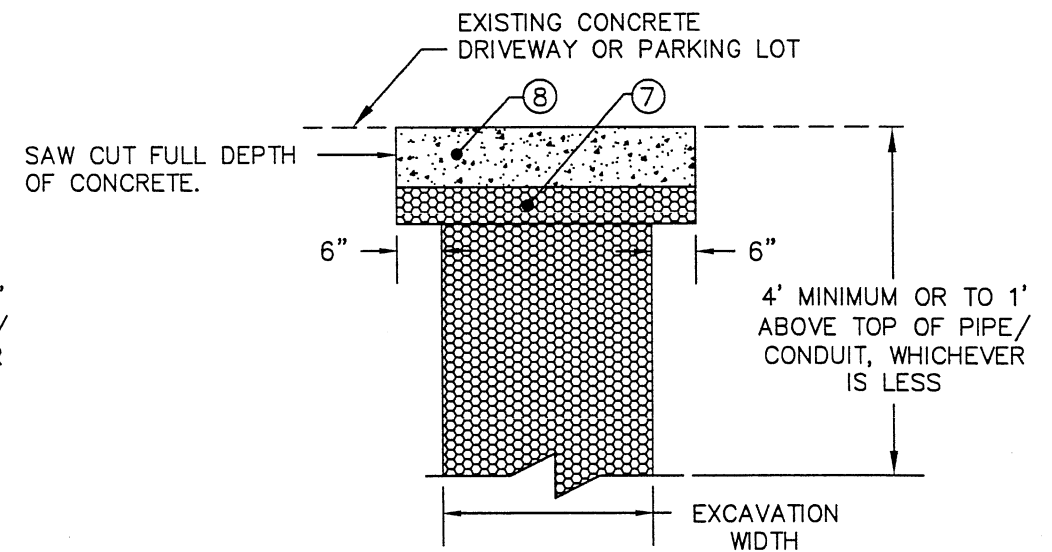

CONCRETE REPAIR

COMMERCIAL DRIVEWAY AND HEAVY DUTY PARKING LOT

F:\STDDWG\REPAIR DETAILS\REPEDET(DRWY-PRKGLT).dwg

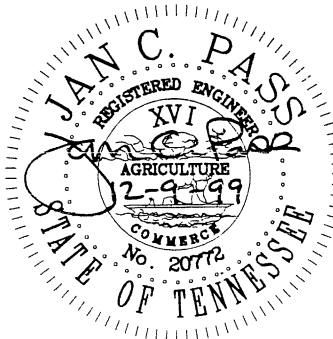
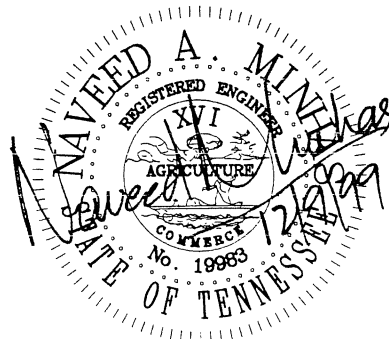

CITY OF CHATTANOOGA AND HAMILTON COUNTY		
REPAIR DETAILS (DRIVEWAY/PARKING LOT)		
	DATE OF ORIGINAL ISSUE	
0	INITIAL ISSUE	12/10/99
NO.	REVISION	DATE
	DECEMBER 10, 1999	STANDARD NUMBER: SD-703.01